

INSTALLATION INSTRUCTIONS

NI SCXI™-1377

Terminal Block for the NI SCXI-1130

This guide describes how to install and connect signals to the National Instruments SCXI-1377 terminal block to configure the SCXI-1130 as a:

- 256x1, 1-wire multiplexer
- 128x1, 2-wire multiplexer
- 64x1, 4-wire multiplexer
- Multiplexer or matrix configuration using the Independent topology

Refer to the *NI Switches Getting Started Guide* to determine when to install the terminal block.

Introduction

The SCXI-1377 terminal block installs in front of the SCXI-1130 switch module. The SCXI-1377 uses spring terminals and screw terminals to connect signals to the switch. Screw terminals for the trigger input and trigger output signals are also available.

Conventions

The following conventions are used in this guide:

»

The » symbol leads you through nested menu items and dialog box options to a final action. The sequence **File»Page Setup»Options** directs you to pull down the **File** menu, select the **Page Setup** item, and select **Options** from the last dialog box.



This icon denotes a tip, which alerts you to advisory information.



This icon denotes a note, which alerts you to important information.



This icon denotes a caution, which advises you of precautions to take to avoid injury, data loss, or a system crash.

bold

Bold text denotes items that you must select or click in the software, such as menu items and dialog box options. Bold text also denotes parameter names and information on hardware labels.

italic

Italic text denotes variables, emphasis, a cross reference, or an introduction to a key concept. This font also denotes text that is a placeholder for a word or value that you must supply.

monospace

Text in this font denotes text or characters that you should enter from the keyboard, sections of code, programming examples, and syntax examples. This font is also used for the proper names of disk drives, paths, directories, programs, subprograms, subroutines, device names, functions, operations, variables, filenames and extensions, and code excerpts.

1. Unpack the Terminal Block

To avoid damage when you handle the terminal block, take the following precautions:



Caution *Never* touch the exposed pins of connectors.

- Ground yourself using a grounding strap or by touching a grounded object.
- Touch the antistatic package to a metal part of the chassis before you remove the terminal block from the package.

Remove the terminal block from the package and inspect the terminal block for loose components or any sign of damage. Notify NI if the terminal block appears damaged in any way. Do *not* install a damaged terminal block on a switch module.

Store the terminal block in the antistatic package when not in use.

2. Verify the Components

Make sure you have the following:

- NI SCXI-1377 terminal block
- SCXI chassis
- NI SCXI-1130 switch module

- 1/8 inch flathead screwdriver
- Phillips screwdriver
- Wire cutter
- Wire insulation stripper



Tip NI recommends using 28 AWG wire (ribbon or discrete) for use with the NI SCXI-1377 terminal block.

3. Connect Signals

To connect signals to the terminal block, refer to Figures 1 and 2 while completing the following steps:

1. Prepare the signal wire by stripping the insulation no more than 7 mm.
2. Remove the top cover screw.
3. Unsnap and remove the top cover.
4. Loosen the two strain-relief screws on the strain-relief assembly and remove the top strain-relief bar.
5. Run the signal wires through the strain-relief opening.
6. Open each terminal by pressing the spring pad with a flathead screwdriver. Insert the stripped end of the wire fully into the terminal. Release the spring pad to secure the wire. No bare wire should extend past the spring terminal. Exposed wire increases the risk of a short-circuit causing a failure.



Note When connecting signals to the NI SCXI-1377, refer to Tables 1, 2, and 3 to determine where to connect signals for the chosen topology.

7. Replace the strain-relief bar and tighten the two screws on the strain-relief assembly to secure the cables.
8. Reinstall the top cover.
9. Replace the top cover screw.

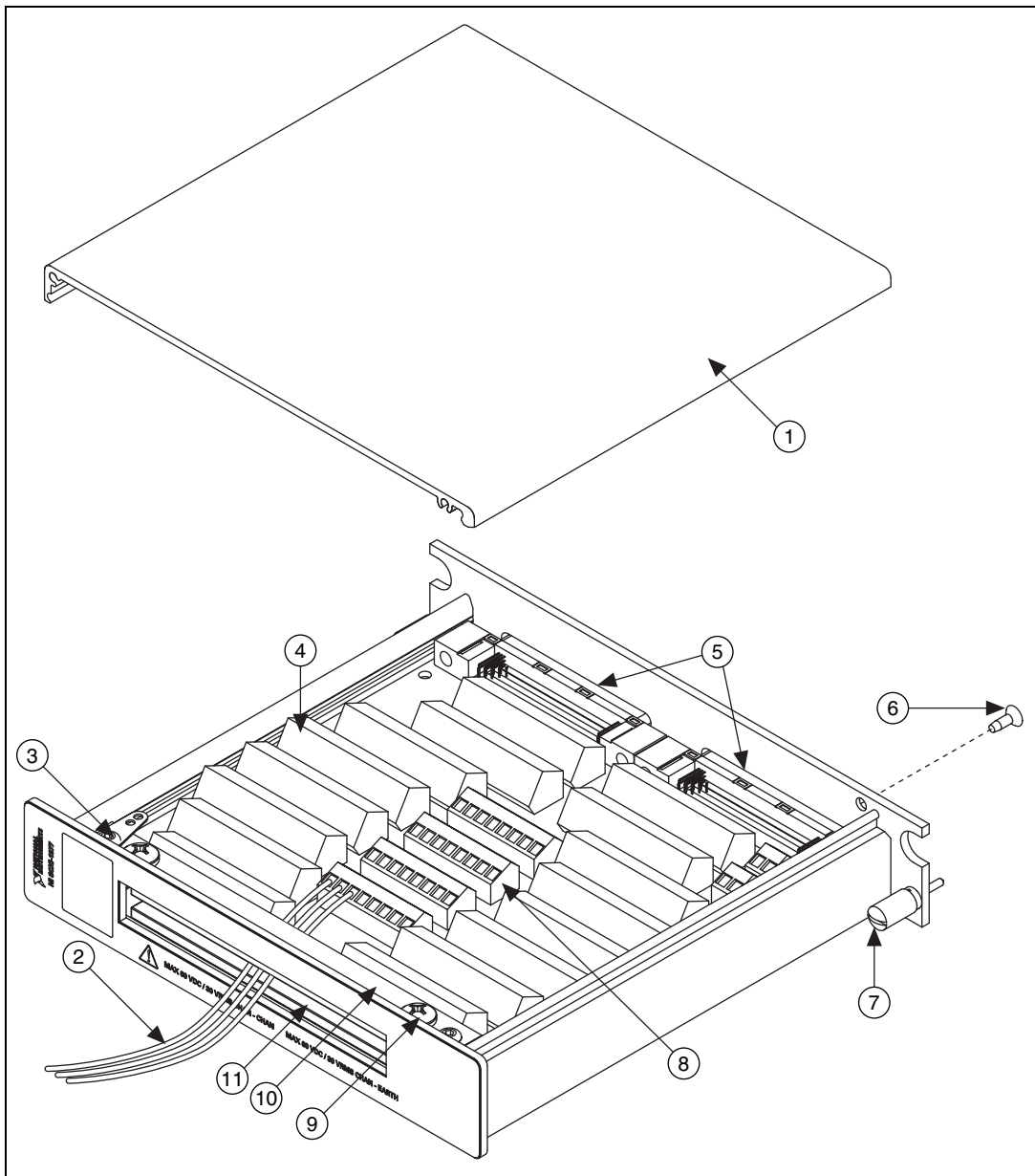

- | | |
|----------------------------|--------------------------|
| 1 Terminal Block Top Cover | 7 Thumbscrew |
| 2 Signal Wires | 8 Screw Terminals |
| 3 Safety Ground Lug | 9 10-32 × 3/4-Inch Screw |
| 4 Spring Terminals | 10 Strain-Relief Bar |
| 5 Rear Connector | 11 Strain-Relief Opening |
| 6 Top Cover Screw | |

Figure 1. SCXI-1377 Terminal Block

NI SCXI-1377 Terminal Reference Guide

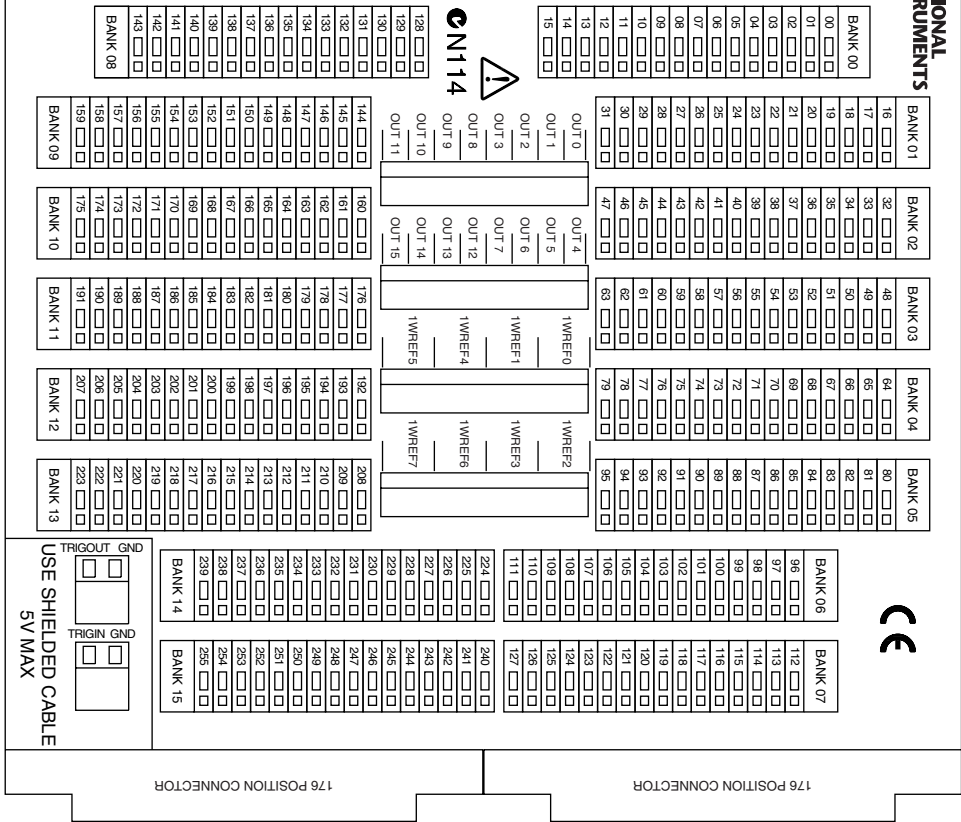

Figure 2. SCXI-1377 Terminal Block Signal Connections

Table 1. 256x1, 1-Wire Multiplexer Topology Mapping

Software	Hardware	Software	Hardware	Software	Hardware	Software	Hardware
com0	OUT 0	ch64	CH 64	ch128	CH 128	ch192	CH 192
ch0	CH 00	ch65	CH 65	ch129	CH 129	ch193	CH 193
ch1	CH 01	ch66	CH 66	ch130	CH 130	ch194	CH 194
ch2	CH 02	ch67	CH 67	ch131	CH 131	ch195	CH 195
ch3	CH 03	ch68	CH 68	ch132	CH 132	ch196	CH 196
ch4	CH 04	ch69	CH 69	ch133	CH 133	ch197	CH 197
ch5	CH 05	ch70	CH 70	ch134	CH 134	ch198	CH 198
ch6	CH 06	ch71	CH 71	ch135	CH 135	ch199	CH 199
ch7	CH 07	ch72	CH 72	ch136	CH 136	ch200	CH 200
ch8	CH 08	ch73	CH 73	ch137	CH 137	ch201	CH 201
ch9	CH 09	ch74	CH 74	ch138	CH 138	ch202	CH 202
ch10	CH 10	ch75	CH 75	ch139	CH 139	ch203	CH 203
ch11	CH 11	ch76	CH 76	ch140	CH 140	ch204	CH 204
ch12	CH 12	ch77	CH 77	ch141	CH 141	ch205	CH 205
ch13	CH 13	ch78	CH 78	ch142	CH 142	ch206	CH 206
ch14	CH 14	ch79	CH 79	ch143	CH 143	ch207	CH 207
ch15	CH 15	ch80	CH 80	ch144	CH 144	ch208	CH 208
ch16	CH 16	ch81	CH 81	ch145	CH 145	ch209	CH 209
ch17	CH 17	ch82	CH 82	ch146	CH 146	ch210	CH 210
ch18	CH 18	ch83	CH 83	ch147	CH 147	ch211	CH 211
ch19	CH 19	ch84	CH 84	ch148	CH 148	ch212	CH 212
ch20	CH 20	ch85	CH 85	ch149	CH 149	ch213	CH 213
ch21	CH 21	ch86	CH 86	ch150	CH 150	ch214	CH 214
ch22	CH 22	ch87	CH 87	ch151	CH 151	ch215	CH 215
ch23	CH 23	ch88	CH 88	ch152	CH 152	ch216	CH 216
ch24	CH 24	ch89	CH 89	ch153	CH 153	ch217	CH 217
ch25	CH 25	ch90	CH 90	ch154	CH 154	ch218	CH 218
ch26	CH 26	ch91	CH 91	ch155	CH 155	ch219	CH 219
ch27	CH 27	ch92	CH 92	ch156	CH 156	ch220	CH 220
ch28	CH 28	ch93	CH 93	ch157	CH 157	ch221	CH 221
ch29	CH 29	ch94	CH 94	ch158	CH 158	ch222	CH 222

Table 1. 256x1, 1-Wire Multiplexer Topology Mapping (Continued)

Software	Hardware	Software	Hardware	Software	Hardware	Software	Hardware
ch30	CH 30	ch95	CH 95	ch159	CH 159	ch223	CH 223
ch31	CH 31	ch96	CH 96	ch160	CH 160	ch224	CH 224
ch32	CH 32	ch97	CH 97	ch161	CH 161	ch225	CH 225
ch33	CH 33	ch98	CH 98	ch162	CH 162	ch226	CH 226
ch34	CH 34	ch99	CH 99	ch163	CH 163	ch227	CH 227
ch35	CH 35	ch100	CH 100	ch164	CH 164	ch228	CH 228
ch36	CH 36	ch101	CH 101	ch165	CH 165	ch229	CH 229
ch37	CH 37	ch102	CH 102	ch166	CH 166	ch230	CH 230
ch38	CH 38	ch103	CH 103	ch167	CH 167	ch231	CH 231
ch39	CH 39	ch104	CH 104	ch168	CH 168	ch232	CH 232
ch40	CH 40	ch105	CH 105	ch169	CH 169	ch233	CH 233
ch41	CH 41	ch106	CH 106	ch170	CH 170	ch234	CH 234
ch42	CH 42	ch107	CH 107	ch171	CH 171	ch235	CH 235
ch43	CH 43	ch108	CH 108	ch172	CH 172	ch236	CH 236
ch44	CH 44	ch109	CH 109	ch173	CH 173	ch237	CH 237
ch45	CH 45	ch110	CH 110	ch174	CH 174	ch238	CH 238
ch46	CH 46	ch111	CH 111	ch175	CH 175	ch239	CH 239
ch47	CH 47	ch112	CH 112	ch176	CH 176	ch240	CH 240
ch48	CH 48	ch113	CH 113	ch177	CH 177	ch241	CH 241
ch49	CH 49	ch114	CH 114	ch178	CH 178	ch242	CH 242
ch50	CH 50	ch115	CH 115	ch179	CH 179	ch243	CH 243
ch51	CH 51	ch116	CH 116	ch180	CH 180	ch244	CH 244
ch52	CH 52	ch117	CH 117	ch181	CH 181	ch245	CH 245
ch53	CH 53	ch118	CH 118	ch182	CH 182	ch246	CH 246
ch54	CH 54	ch119	CH 119	ch183	CH 183	ch247	CH 247
ch55	CH 55	ch120	CH 120	ch184	CH 184	ch248	CH 248
ch56	CH 56	ch121	CH 121	ch185	CH 185	ch249	CH 249
ch57	CH 57	ch122	CH 122	ch186	CH 186	ch250	CH 250
ch58	CH 58	ch123	CH 123	ch187	CH 187	ch251	CH 251
ch59	CH 59	ch124	CH 124	ch188	CH 188	ch252	CH 252
ch60	CH 60	ch125	CH 125	ch189	CH 189	ch253	CH 253

Table 1. 256x1, 1-Wire Multiplexer Topology Mapping (Continued)

Software	Hardware	Software	Hardware	Software	Hardware	Software	Hardware
ch61	CH 61	ch126	CH 126	ch190	CH 190	ch254	CH 254
ch62	CH 62	ch127	CH 127	ch191	CH 191	ch255	CH 255
ch63	CH 63						

Table 2. 128x1, 2-Wire Multiplexer Topology Mapping

Software	Hardware		Software	Hardware		Software	Hardware	
	+	-		+	-		+	-
com0	OUT 0	OUT 1	ch42	CH 74	CH 90	ch85	CH 165	CH 181
ch0	CH 00	CH 16	ch43	CH 75	CH 91	ch86	CH 166	CH 182
ch1	CH 01	CH 17	ch44	CH 76	CH 92	ch87	CH 167	CH 183
ch2	CH 02	CH 18	ch45	CH 77	CH 93	ch88	CH 168	CH 184
ch3	CH 03	CH 19	ch46	CH 78	CH 94	ch89	CH 169	CH 185
ch4	CH 04	CH 20	ch47	CH 79	CH 95	ch90	CH 170	CH 186
ch5	CH 05	CH 21	ch48	CH 96	CH 112	ch91	CH 171	CH 187
ch6	CH 06	CH 22	ch49	CH 97	CH 113	ch92	CH 172	CH 188
ch7	CH 07	CH 23	ch50	CH 98	CH 114	ch93	CH 173	CH 189
ch8	CH 08	CH 24	ch51	CH 99	CH 115	ch94	CH 174	CH 190
ch9	CH 09	CH 25	ch52	CH 100	CH 116	ch95	CH 175	CH 191
ch10	CH 10	CH 26	ch53	CH 101	CH 117	ch96	CH 192	CH 208
ch11	CH 11	CH 27	ch54	CH 102	CH 118	ch97	CH 193	CH 209
ch12	CH 12	CH 28	ch55	CH 103	CH 119	ch98	CH 194	CH 210
ch13	CH 13	CH 29	ch56	CH 104	CH 120	ch99	CH 195	CH 211
ch14	CH 14	CH 30	ch57	CH 105	CH 121	ch100	CH 196	CH 212
ch15	CH 15	CH 31	ch58	CH 106	CH 122	ch101	CH 197	CH 213
ch16	CH 32	CH 48	ch59	CH 107	CH 123	ch102	CH 198	CH 214
ch17	CH 33	CH 49	ch60	CH 108	CH 124	ch103	CH 199	CH 215
ch18	CH 34	CH 50	ch61	CH 109	CH 125	ch104	CH 200	CH 216
ch19	CH 35	CH 51	ch62	CH 110	CH 126	ch105	CH 201	CH 217
ch20	CH 36	CH 52	ch63	CH 111	CH 127	ch106	CH 202	CH 218
ch21	CH 37	CH 53	ch64	CH 128	CH 144	ch107	CH 203	CH 219
ch22	CH 38	CH 54	ch65	CH 129	CH 145	ch108	CH 204	CH 220
ch23	CH 39	CH 55	ch66	CH 130	CH 146	ch109	CH 205	CH 221

Table 2. 128x1, 2-Wire Multiplexer Topology Mapping (Continued)

Software	Hardware		Software	Hardware		Software	Hardware	
	+	-		+	-		+	-
ch24	CH 40	CH 56	ch67	CH 131	CH 147	ch110	CH 206	CH 222
ch25	CH 41	CH 57	ch68	CH 132	CH 148	ch111	CH 207	CH 223
ch26	CH 42	CH 58	ch69	CH 133	CH 149	ch112	CH 224	CH 240
ch27	CH 43	CH 59	ch70	CH 134	CH 150	ch113	CH 225	CH 241
ch28	CH 44	CH 60	ch71	CH 135	CH 151	ch114	CH 226	CH 242
ch29	CH 45	CH 61	ch72	CH 136	CH 152	ch115	CH 227	CH 243
ch30	CH 46	CH 62	ch73	CH 137	CH 153	ch116	CH 228	CH 244
ch31	CH 47	CH 63	ch74	CH 138	CH 154	ch117	CH 229	CH 245
ch32	CH 64	CH 80	ch75	CH 139	CH 155	ch118	CH 230	CH 246
ch33	CH 65	CH 81	ch76	CH 140	CH 156	ch119	CH 231	CH 247
ch34	CH 66	CH 82	ch77	CH 141	CH 157	ch120	CH 232	CH 248
ch35	CH 67	CH 83	ch78	CH 142	CH 158	ch121	CH 233	CH 249
ch36	CH 68	CH 84	ch79	CH 143	CH 159	ch122	CH 234	CH 250
ch37	CH 69	CH 85	ch80	CH 160	CH 176	ch123	CH 235	CH 251
ch38	CH 70	CH 86	ch81	CH 161	CH 177	ch124	CH 236	CH 252
ch39	CH 71	CH 87	ch82	CH 162	CH 178	ch125	CH 237	CH 253
ch40	CH 72	CH 88	ch83	CH 163	CH 179	ch126	CH 238	CH 254
ch41	CH 73	CH 89	ch84	CH 164	CH 180	ch127	CH 239	CH 255

Table 3. 64x1, 4-Wire Multiplexer Topology Mapping

Software	Hardware				Software	Hardware			
	A+	A-	B+	B-		A+	A-	B+	B-
com0	OUT 0	OUT 1	OUT 4	OUT 5	ch32	CH 128	CH 144	CH 192	CH 208
ch0	CH 00	CH 16	CH 64	CH 80	ch33	CH 129	CH 145	CH 193	CH 209
ch1	CH 01	CH 17	CH 65	CH 81	ch34	CH 130	CH 146	CH 194	CH 210
ch2	CH 02	CH 18	CH 66	CH 82	ch35	CH 131	CH 147	CH 195	CH 211
ch3	CH 03	CH 19	CH 67	CH 83	ch36	CH 132	CH 148	CH 196	CH 212
ch4	CH 04	CH 20	CH 68	CH 84	ch37	CH 133	CH 149	CH 197	CH 213
ch5	CH 05	CH 21	CH 69	CH 85	ch38	CH 134	CH 150	CH 198	CH 214
ch6	CH 06	CH 22	CH 70	CH 86	ch39	CH 135	CH 151	CH 199	CH 215

Table 3. 64x1, 4-Wire Multiplexer Topology Mapping (Continued)

Software	Hardware			
	A+	A-	B+	B-
ch7	CH 07	CH 23	CH 71	CH 87
ch8	CH 08	CH 24	CH 72	CH 88
ch9	CH 09	CH 25	CH 73	CH 89
ch10	CH 10	CH 26	CH 74	CH 90
ch11	CH 11	CH 27	CH 75	CH 91
ch12	CH 12	CH 28	CH 76	CH 92
ch13	CH 13	CH 29	CH 77	CH 93
ch14	CH 14	CH 30	CH 78	CH 94
ch15	CH 15	CH 31	CH 79	CH 95
ch16	CH 32	CH 48	CH 96	CH 112
ch17	CH 33	CH 49	CH 97	CH 113
ch18	CH 34	CH 50	CH 98	CH 114
ch19	CH 35	CH 51	CH 99	CH 115
ch20	CH 36	CH 52	CH 100	CH 116
ch21	CH 37	CH 53	CH 101	CH 117
ch22	CH 38	CH 54	CH 102	CH 118
ch23	CH 39	CH 55	CH 103	CH 119
ch24	CH 40	CH 56	CH 104	CH 120
ch25	CH 41	CH 57	CH 105	CH 121
ch26	CH 42	CH 58	CH 106	CH 122
ch27	CH 43	CH 59	CH 107	CH 123
ch28	CH 44	CH 60	CH 108	CH 124
ch29	CH 45	CH 61	CH 109	CH 125
ch30	CH 46	CH 62	CH 110	CH 126
ch31	CH 47	CH 63	CH 111	CH 127

Software	Hardware			
	A+	A-	B+	B-
ch40	CH 136	CH 152	CH 200	CH 216
ch41	CH 137	CH 153	CH 201	CH 217
ch42	CH 138	CH 154	CH 202	CH 218
ch43	CH 139	CH 155	CH 203	CH 219
ch44	CH 140	CH 156	CH 204	CH 220
ch45	CH 141	CH 157	CH 205	CH 221
ch46	CH 142	CH 158	CH 206	CH 222
ch47	CH 143	CH 159	CH 207	CH 223
ch48	CH 160	CH 176	CH 224	CH 240
ch49	CH 161	CH 177	CH 225	CH 241
ch50	CH 162	CH 178	CH 226	CH 242
ch51	CH 163	CH 179	CH 227	CH 243
ch52	CH 164	CH 180	CH 228	CH 244
ch53	CH 165	CH 181	CH 229	CH 245
ch54	CH 166	CH 182	CH 230	CH 246
ch55	CH 167	CH 183	CH 231	CH 247
ch56	CH 168	CH 184	CH 232	CH 248
ch57	CH 169	CH 185	CH 233	CH 249
ch58	CH 170	CH 186	CH 234	CH 250
ch59	CH 171	CH 187	CH 235	CH 251
ch60	CH 172	CH 188	CH 236	CH 252
ch61	CH 173	CH 189	CH 237	CH 253
ch62	CH 174	CH 190	CH 238	CH 254
ch63	CH 175	CH 191	CH 239	CH 255

4. Install the Terminal Block

To connect the SCXI-1377 terminal block to the SCXI-1130 front panel, refer to Figure 3 and complete the following steps (the SCXI-1130 should already be installed in an SCXI chassis):

1. Plug the SCXI-1377 onto the front connectors of the SCXI-1130.
2. Tighten the top and bottom thumbscrews on the back of the terminal block rear panel to hold it securely in place.

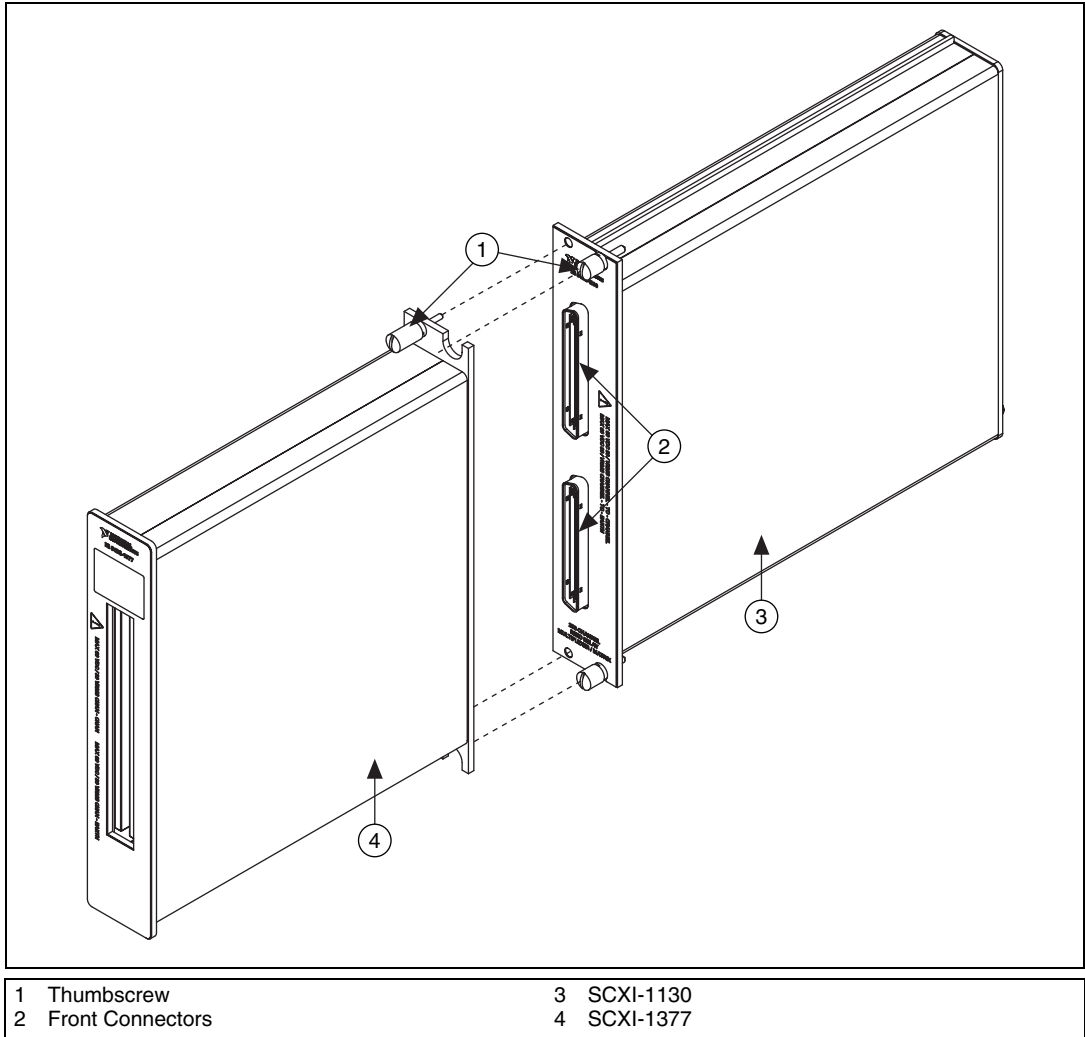

Figure 3. Installing the SCXI-1377 Terminal Block

Compliance and Certifications

Safety

This product is designed to meet the requirements of the following standards of safety for electrical equipment for measurement, control, and laboratory use:

- IEC 61010-1, EN 61010-1
- UL 3111-1, UL 61010B-1
- CAN/CSA C22.2 No. 1010.1



Note For UL and other safety certifications, refer to the product label, or visit ni.com/hardref.nsf, search by model number or product line, and click the appropriate link in the Certification column.

Electromagnetic Compatibility

Emissions	EN 55011 Class A at 10 m FCC Part 15A above 1 GHz
Immunity	EN 61326:1997 + A2:2001, Table 1
EMC/EMI	CE, C-Tick, and FCC Part 15 (Class A) Compliant



Note For EMC compliance, you *must* operate this device with shielded cabling.

CE Compliance

This product meets the essential requirements of applicable European Directives, as amended for CE marking, as follows:

Low-Voltage Directive (safety).....	73/23/EEC
Electromagnetic Compatibility Directive (EMC)	89/336/EEC



Note Refer to the Declaration of Conformity (DoC) for this product for any additional regulatory compliance information. To obtain the DoC for this product, visit ni.com/hardref.nsf, search by model number or product line, and click the appropriate link in the Certification column.

